

Section 3 – Dairy/Deli–Produits laitiers/Charc.

DD-05

Modèle PSMF Model

Lift-up Curved Glass, Deli and Seafood Merchandisers (Forced Air) (48" H)
 Prés. à vitre courbée relevable pour charc. et fruits de mer (Air forcé) (48" H)

Top View / Vue de plan

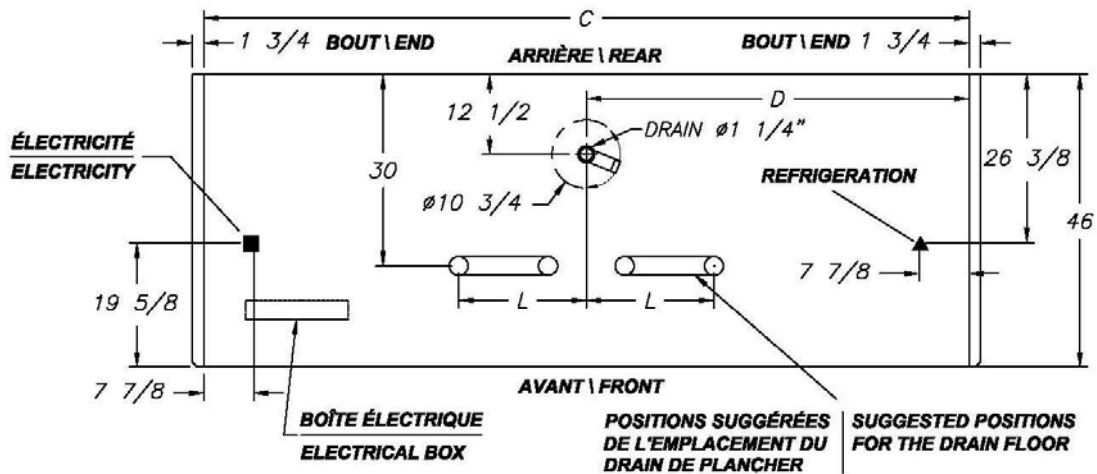

C=Comptoir	48"	72"	96"	120"	144"
D=Position	24"	32"	44"	60"	72"
L=Longueur	16"	20"	24"	20"	20"

45° EXTERIOR CORNER
 45° COIN EXTERIEUR
 DRAIN STANDARD

45° INTERIOR CORNER
 45° COIN INTERIEUR
 DRAIN STANDARD

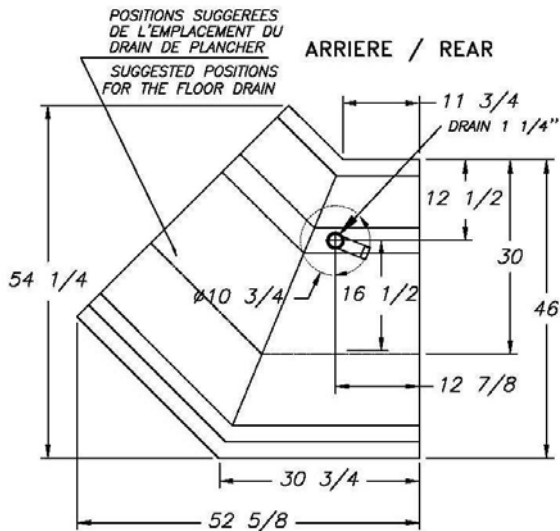

DEVANT-CLIENT / FRONT-CUSTOMER

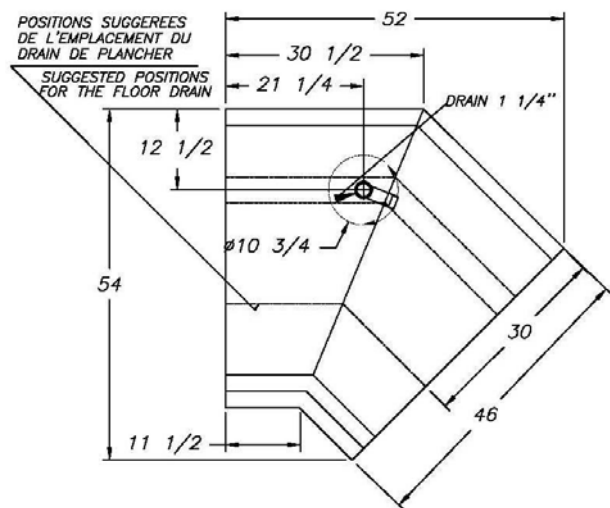

DEVANT-CLIENT / FRONT-CUSTOMER



Section 3 – Dairy/Deli–Produits laitiers/Charc.

DD-05

Modèle PSMF Model

Lift-up Curved Glass, Deli and Seafood Merchandisers (Forced Air) (48" H)
Prés. à vitre courbée relevable pour charc. et fruits de mer (Air forcé) (48" H)

Refrigeration and Electrical Data / Données sur la réfrigération et l'électricité

Refrigeration Data			Defrost Data/Données de dégivrage						
Case Model	BTU/hr/ft*	Evaporator	# of	Hot Gas		Electric		Off Time	
		Temp.	Defrosts	Temp.	Failsafe	Temp.	Failsafe	Temp.	Failsafe
		(F)		Term.(F)	Time (min)	Term.(F)	Time (min)	Term.(F)	Time (min)
PSMF	370	20	2	50	20	nr	nr	50	90
Corner/Coin	BTU/hr/Case								
45° int.	1110	20	2	50	20	nr	nr	50	90
45° ext.	1390	20	2	50	20	nr	nr	50	90

Note: *BTU/hr/ft are for parallel operation. For sizing conventional/individual units multiply by 1.08.

Lighting Data/Données d'éclairage (120V)											
PSMF		4 ft		6 ft		8 ft		10 ft		12 ft	
		Watts	Amps	Watts	Amps	Watts	Amps	Watts	Amps	Watts	Amps
	Lighting/Eclairage-Top										
	2 rows	57	0.48	67	0.56	121	1	157	1.3	185	1.54
	Handrail Lighting - Bottom/Eclairage du seuil frontal - Partie inférieure										
	1 row	25	0.21	42	0.35	57	0.47	75	0.62	89	0.74
	Total	82	0.69	109	0.91	178	1.47	232	1.92	274	2.28

Electrical Data/Données électriques										
Case Model	Length	Fans/Ventilateurs			Éléments A/S heaters		Defrost heaters/Éléments de dégivrage			
		No of fans	120 V		120 V		208 V		240 V	
			Watts	Amps	Watts	Amps	Watts	Amps	Watts	Amps
PSMF	4 ft	1	9	0.55	N/A	N/A	N/A	N/A	N/A	N/A
	6 ft	2	18	1.1	---	---	---	---	---	---
	8 ft	2	18	1.1	---	---	---	---	---	---
	10 ft	3	27	1.65	---	---	---	---	---	---
	12 ft	3	27	1.65	---	---	---	---	---	---

Note : Ces présentoirs sont conçus pour une utilisation en magasin où la température et l'humidité n'excèdent pas 75°F et 55% H.R. La compagnie IFI est engagée dans une politique d'amélioration de ses produits. Les spécifications sont sujettes à changements sans préavis.

Note: These merchandisers are designed for use in stores where temperature and humidity do not exceed 75°F and 55% R.H. As continued product improvement is a policy of IFI, specifications are subject to change without notice.

